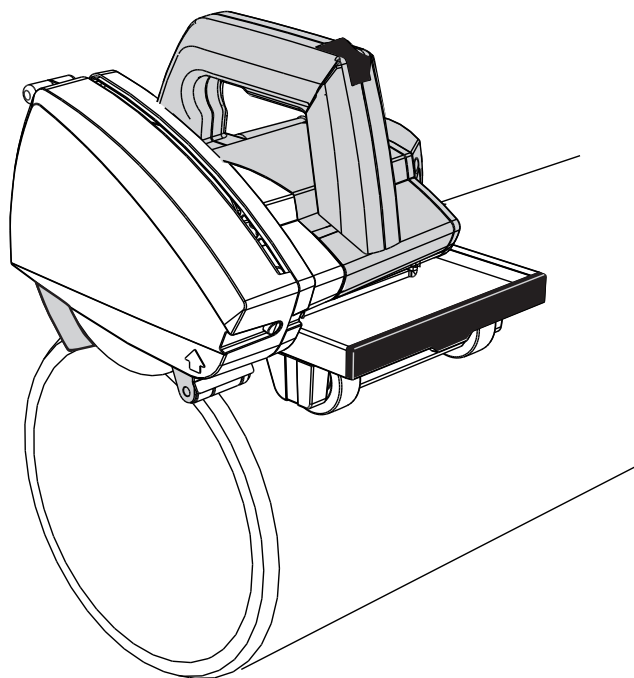


exact

PipeCut P400 Plastic



EN Operating Instructions

5-16

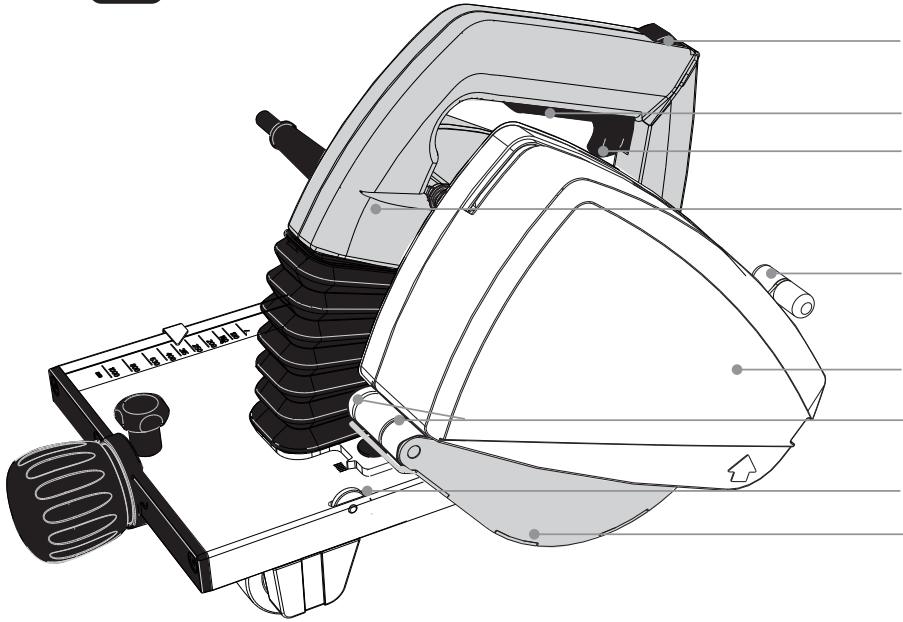
Exact PipeCut P400

Blade information for Exact PipeCut saws

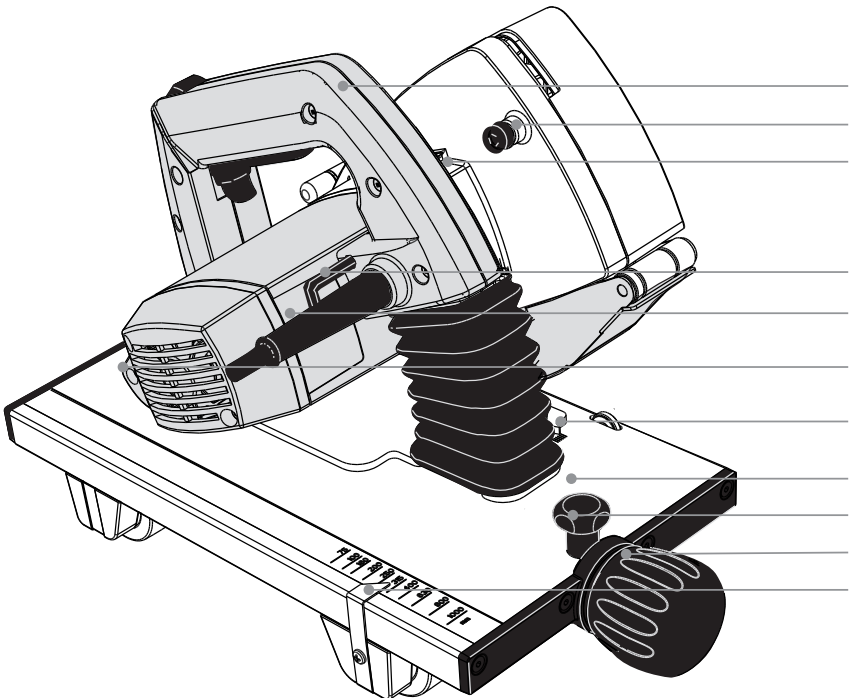
There are two types of blades for Exact PipeCut P400 pipe saw:

- 1) TCT P150 blade is designed for cutting plastic pipes with P400 pipe saw. TCT blades can be reshaped a few times.
- 2) CutBevel blade is designed to cut and bevel plastic pipes in one process. The bevelling blades can be turned around to get a new sharp cutting edge. There is also an upgrade kit available for CutBevel. It contains one cutting blade and 8 pcs bevelling blades and the screws needed to fix these blades to the blade body. By changing these one gets a blade that works like a new.

A



- 1.
- 2.
- 3.
- 4.
- 5.
- 6.
- 7.
- 8.
- 9.



- 10.
- 11.
- 12.
- 13.
- 14.
- 15.
- 16.
- 17.
- 18.
- 19.
- 20.

Declaration of Conformity

We declare under our sole responsibility that the products described under "Technical Data" are in conformity with the following standards or standardization documents: EN60745 according to the provisions of the directives 2004/108/EC, 2006/42/EC.

For more information, please contact Exact Tools at the following address.

The technical file is available at the address underneath.

The person authorized to compile the technical file:

Marko Törrönen, R&D Manager (marko.torronen@exacttools.com)

Helsinki, 1.9.2011



Seppo Makkonen, Managing director

Exact Tools Oy

Särkiniementie 5 B 64

FI-00210 Helsinki

Finland

Contents

- 6. Technical data
- 6. Package contents

Safety

- 7. Safety instructions

Operation

- 10. Functional description and intended use
- 10. Product features
- 11. Before operating the tool
- 11. Connection to the mains power supply
- 11. Setting the pipe on supports
- 11. Setting and marking the cutting point
- 11. To start sawing
- 12. Piercing the pipe wall
- 12. Sawing around a pipe
- 13. Overload protection
- 13. Straightness of cut and adjusting wheel

14. Installing and changing the saw blade

14. Service and maintenance instructions

16. Environment /Disposal

16. Guarantee/Guarantee conditions

16. Tips for users

Exploded view (separate attachment)

exact
Pipe Cutting System

Definitions: Safety guidelines

The definitions below describe the level of severity for each signal word. Please read the manual and pay attention to these symbols.



DANGER: Indicates an imminently hazardous situation which, if not avoided, **will** result in **death or serious injury**.



WARNING: Indicates a potentially hazardous situation which, if not avoided, **could** result in **death or serious injury**.



CAUTION: Indicates a potentially hazardous situation which, if not avoided, **may** result in **minor or moderate injury**.



NOTICE: Indicates a practice **not related to personal injury** which, if not avoided, **may** result in **property damage**.



Denotes risk of electric shock.

Operating, safety, and servicing instructions

Please read this operating, safety, and servicing instructions carefully before using the pipe saw. Also store this instruction book somewhere accessible to everyone using the pipe saw. In addition to these instructions, always follow the official work, health and safety regulations. The Exact PipeCut is meant for professional use only.

Technical data

	Pipecut P400
Voltage	220 - 240 V / 50-60 Hz (also 110 V)
Power	1010 W
No-Load speed	4000 r/min
Intermittent operation	S3 25% 10min (2,5 min ON /7,5 min OFF)
Blade diameter	150 mm / 148 mm in the beveling blade
Mounting bore	62 mm
Weight	6,6 kg
Range of use Ø	50 mm – 400 mm
Max. pipe wall	25 mm cut, 22 mm cut bevel
Protection class	□ / II
Spindle lock	YES
Speed preselection	NO
Constant electronic control	NO
Overload Protection	YES
Reduced starting current	NO
Vibration emission value ah	2,6 m/s ²
Uncertainty of Vibration emission value K	1,5 m/s ²
LWA (sound power)	100 dB
LpA (sound pressure)	89 dB
LpC (highest peak of sound pressure)	103dB

The values given are valid for nominal voltages [U] of 230/240V. For lower voltage and models for specific countries, these values can vary.

Please observe the article number on the type plate of your machine. The trade names of the individual machines may vary. Only for power tools without reduced starting current: Starting cycles generate brief voltage drops. Interference with other equipment/machines may occur in case of unfavourable mains system conditions. Malfunctions are not to be expected for system impedances below 0,36 ohm.

Noise/Vibration Information

Measured values determined according to EN60745-1:2009 + A11:210 ja EN60745-2-3:210.

Wear hearing protection!

The test was performed using Ø200 mm PVC pipe that has 5,9 mm thick wall.

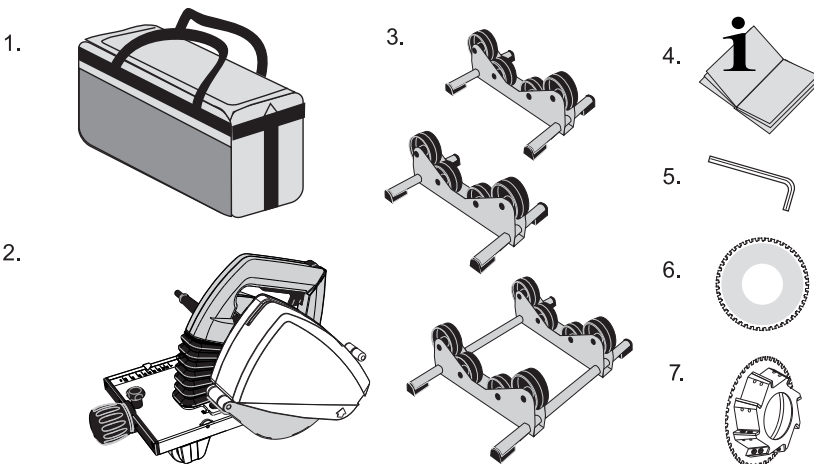
The vibration emission level given in this information sheet has been measured in accordance with a standardised test given in EN 60745 and may be used to compare one tool with another. It may be used for a preliminary assessment of exposure.

⚠ WARNING: The declared vibration emission level represents the main applications of the tool. However if the tool is used for different applications, with different accessories or poorly maintained, the vibration emission may differ. This may significantly increase the exposure level over the total working period. An estimation of the level of exposure to vibration should also take into account the times when the tool is switched off or when it is running but not actually doing the job. This may significantly reduce the exposure level over the total working period. Identify additional safety measures to protect the operator from the effects of vibration such as: maintain the tool and the accessories, keep the hands warm, organisation of work patterns.

Exact PipeCut P400 pipe saw
Package contents:

Please check the package contains the following items:

1. PipeCut shoulder bag
2. Exact PipeCut P400 pipe saw
3. Pipe supports: 1 double and 2 single
4. Operating instructions
5. Allen key 5 mm fixed to the handle
6. TCT blade 150 x 62 fitted on the machine
7. Cut Bevel blade in the bag



General power tool safety warnings



WARNING: Read all safety warnings and all instructions. Failure to follow the warnings and instructions may result in electric shock, fire and/or serious injury

Save all warnings and instructions for future reference.

The term "power tool" in the warnings refers to your mains-operated (corded) power tool or battery-operated (cordless) power tool.

1. Work area safety

- a) **Keep work area clean and well lit.** Cluttered or dark areas invite accidents.
- b) **Do not operate power tools in explosive atmospheres, such as in the presence of flammable liquids, gases or dust.** Power tools create sparks which may ignite the dust or fumes.
- c) **Keep children and bystanders away while operating a power tool.** Distractions can cause you to lose control.

2. Electrical safety

- a) **Power tool plugs must match the outlet. Never modify the plug in any way. Do not use any adapter plugs with earthed (grounded) power tools.** Unmodified plugs and matching outlets will reduce risk of electric shock.
- b) **Avoid body contact with earthed or grounded surfaces, such as pipes, radiators, ranges and refrigerators.** There is an increased risk of electric shock if your body is earthed or grounded.
- c) **Do not expose power tools to rain or wet conditions.** Water entering a power tool will increase the risk of electric shock.
- d) **Do not abuse the cord. Never use the cord for carrying, pulling or unplugging the power tool. Keep cord away from heat, oil, sharp edges and moving parts.** Damaged or entangled cords increase the risk of electric shock.
- e) **When operating a power tool outdoors, use an extension cord suitable for outdoor use.** Use of a cord suitable for outdoor use reduces the risk of electric shock.
- f) **If operating a power tool in a damp location is unavoidable, use a residual current device (RCD) protected supply.** Use of an RCD reduces the risk of electric shock.

3. Personal safety

- a) **Stay alert, watch what you are doing and use common sense when operating a power tool. Do not use a power tool while you are tired or under the influence of drugs, alcohol or medication.** A moment of inattention while operating power tools may result in serious personal injury.
- b) **Use personal protective equipment. Always wear eye protection.** Protective equipment such as dust mask, non-skid safety shoes, hard hat, or hearing protection used for appropriate conditions will reduce personal injuries.
- c) **Prevent unintentional starting. Ensure the**

switch is in the off-position before connecting to power source, picking up or carrying the tool. Carrying power tools with your finger on the switch or energising power tools that have the switch on invites accidents.

- d) **Remove any adjusting key or wrench before turning the power tool on.** A wrench or a key left attached to a rotating part of the power tool may result in personal injury.
- e) **Do not overreach. Keep proper footing and balance at all times.** This enables better control of the power tool in unexpected situations.
- f) **Dress properly. Do not wear loose clothing or jewellery. Keep your hair, clothing and gloves away from moving parts.** Loose clothes, jewellery or long hair can be caught in moving parts.
- g) **If devices are provided for the connection of dust extraction and collection facilities, ensure these are connected and properly used.** Use of dust collection can reduce dust-related hazards.

4. Power tool use and care

- a) **Do not force the power tool. Use the correct power tool for your application.** The correct power tool will do the job better and safer at the rate for which it was designed.
- b) **Do not use the power tool if the switch does not turn it on and off.** Any power tool that cannot be controlled with the switch is dangerous and must be repaired.
- c) **Disconnect the plug from the power source from the power tool before making any adjustments, changing accessories, or storing power tools.** Such preventive safety measures reduce the risk of starting the power tool accidentally.
- d) **Store idle power tools out of the reach of children and do not allow persons unfamiliar with the power tool or these instructions to operate the power tool.** Power tools are dangerous in the hands of untrained users.
- e) **Maintain power tools. Check for misalignment or binding of moving parts, breakage of parts and any other condition that may affect the power tool's operation. If damaged, have the power tool repaired before use.** Many accidents are caused by poorly maintained power tools.
- f) **Keep cutting tools sharp and clean.** Properly maintained cutting tools with sharp cutting edges are less likely to bind and are easier to control.
- g) **Use the power tool, accessories and tool bits etc. in accordance with these instructions, taking into account the working conditions and the work to be performed.** Use of the power tool for operations different from those intended could result in a hazardous situation.

5. Service

Have your power tool serviced by a qualified repair person using only identical replacement parts. This will ensure that the safety of the power tool is maintained.

Safety warnings for circular saws

- a)  **DANGER: Keep hands away from cutting area and the blade. Keep your second hand on motor housing.** If both hands are holding the saw, they cannot be cut by the blade.

NOTE: For circular saws with 140 mm or smaller diameter blades, the "Keep your second hand on auxiliary handle, or motor housing" may be omitted.

- b) **Do not reach underneath the workpiece.** The guard cannot protect you from the blade below the workpiece.
- c) **Adjust the cutting depth to the thickness of the workpiece.** Less than a full tooth of the blade teeth should be visible below the workpiece.
- d) **Never hold the workpiece being cut in your hands or across your leg. Secure the workpiece to a stable platform.** It is important to support the work properly to minimize body exposure, blade binding, or loss of control.
- e) **Hold the power tool only by the insulated gripping surfaces when performing an operation where the cutting tool may contact hidden wiring or its own cord.** Contact with a "live" wire will also make exposed metal parts of the power tool "live" and shock the operator.
- f) **When ripping always use a rip fence or straight edge guide.** This improves the accuracy of cut and reduces the chance of blade binding
- g) **Always use blades with correct size and shape (diamond versus round) of arbour holes.** Blades that do not match the mounting hardware of the saw will run eccentrically, causing loss of control.
- h) **Never use damaged or incorrect blade washers or bolt.** The blade washers and bolt were specially designed for your saw, for optimum performance and safety of operation.
- i) **Do not reach into the saw dust ejector with your hands.** They could be injured by rotating parts.
- j) **Do not work overhead with the saw.** In this manner you do not have sufficient control over the power tool.
- k) **Do not operate the power tool stationary.** It is not designed for operation with a saw table.
- l) **Do not use high speed steel (HSS) saw blades.** Such saw blades can easily break.
- m) **When working with the machine, always hold it firmly with both hands and provide for a secure stance.** The power tool is guided more secure with both hands.
- n) **Secure the workpiece.** A workpiece supported by pipe holders is held more secure than by hand.
- o) **Always wait until the machine has come to a complete stop before placing it down.** The tool insert can jam and lead to loss of control over the power tool.
- p) **Never use the machine with a damaged cable. Do not touch the damaged cable and pull the mains plug when the cable is damaged while working.** Damaged cables increase the risk of an electric shock.

Further safety instructions for all saws

Causes and operator prevention of kickback:

- Kickback is a sudden reaction to a pinched, bound or misaligned saw blade, causing an uncontrolled saw to lift up and out of the workpiece toward the operator;
- When the blade is pinched or bound tightly by the kerf closing down, the blade stalls and the motor reaction drives the unit rapidly back toward the operator;
- If the blade becomes twisted or misaligned in the cut, the teeth at the back edge of the blade can dig into the top surface of the wood causing the blade to climb out of the kerf and jump back toward the operator.

Kickback is the result of saw misuse and/or incorrect operating procedures or conditions and can be avoided by taking proper precautions as given below:

- a) **Maintain a firm grip with both hands on the saw and position your arms to resist kickback forces. Position your body to either side of the blade, but not in line with the blade.** Kickback could cause the saw to jump backwards, but kickback forces can be controlled by the operator, if proper precautions are taken.

NOTE: For circular saws with 140 mm or smaller diameter blades, the words "with both hands" may be omitted.

- b) **When blade is binding, or when interrupting a cut for any reason, release the trigger and hold the saw motionless in the material until the blade comes to a complete stop.** Never attempt to remove the saw from the work or pull the saw backward while the blade is in motion or kickback may occur. Investigate and take corrective actions to eliminate the cause of blade binding.
- c) **When restarting a saw in the workpiece, centre the saw blade in the kerf and check that saw teeth are not engaged into the material.** If saw blade is binding, it may walk up or kickback from the workpiece as the saw is restarted.
- d) **Support large panels to minimise the risk of blade pinching and kickback.** Large panels tend to sag under their own weight. Supports must be placed under the panel on both sides, near the line of cut and near the edge of the panel.
- e) **Do not use dull or damaged blades.** Unsharpened or improperly set blades produce narrow kerf causing excessive friction, blade binding and kickback.
- f) **Blade depth and bevel adjusting locking levers must be tight and secure before making cut.** If blade adjustment shifts while cutting, it may cause binding and kickback.
- g) **Use extra caution when making a "plunge cut" into existing walls or other blind areas.** The protruding blade may cut objects that can cause kickback.

Safety instructions for plunge type saws

- a) **Check guard for proper closing before each use.** Do not operate the saw if guard does not move freely and enclose the blade instantly. Never clamp or tie the guard with the blade exposed. If saw is accidentally dropped, guard may be bent. Check to make sure that guard moves freely and does not touch the blade or any other part, in all angles and depths of cut.

- b) **Check the operation and condition of the guard return spring.** If the guard and the spring are not operating properly, they must be serviced before use. Guard may operate sluggishly due to damaged parts, gummy deposits, or a build-up of debris.
- c) **Assure that the guide plate of the saw will not shift while performing the "plunge cut" when the blade bevel setting is not at 90°.** Blade shifting sideways will cause binding and likely kick back.
- d) **Always observe that the guard is covering the blade before placing saw down on bench or floor.** An unprotected, coasting blade will cause the saw to walk backwards, cutting whatever is in its path. Be aware of the time it takes for the blade to stop after switch is released.

Additional specific safety rules

The pipe saw must never be used in the following cases, if:

- There is water or another liquid, explosive gases or poisonous chemicals inside the pipe to be cut.
- The power switch is faulty.
- The power cable is faulty,
- The blade is bent.
- The blade is blunt or in poor condition.
- The plastic components are cracked or have parts missing.
- The gripper unit is not properly tightened around the pipe or if it is warped.
- The blade guard cover or moving blade guard has been damaged or removed from the machine.
- The locking mechanisms do not work properly (UNLOCK-button).
- The pipe saw has become wet.

When using the pipe saw, the following factors must always be taken into consideration:

- Support tubes to minimise the risk of blade pinching.
- Ensure that the pipe to be cut is empty.
- Ensure that the blade is correctly installed.
- Ensure that the diameter and thickness of the blade are suitable for the pipe saw and that the blade is suitable for the rpm-range of the machine.
- Never use sideways force to stop the blade, always allow the blade to stop freely.
- Check the attachments of the blade guards.
- Never use excessive force when using the pipe saw.
- Never use the pipe saw to lift the pipe while it is still attached to the pipe.
- Avoid overloading the electric motor.
- Always follow the safety and operating instructions and current regulations.



Functional Description

Read all safety warnings and all instructions. Failure to follow the warnings and instructions

may result in electric shock, fire and/or serious injury.

Intended Use

PipeCut P400:

The Exact Pipe Cut P400 is intended for professional use at any kind of construction sites.

The Exact PipeCut P400 is designed to be used only for plastic pipes with dimensions 50 mm (2") - 400 mm (16"). The maximum wall thickness that the Exact Pipe Cut P400 can cut through is 25 mm (1"). With a Cut Bevel blade the maximum wall thickness is 22 mm (0,9"). With the Exact PipeCut P 400 you can cut pipes made from the different plastic materials, such as PP, PE, PVC, etc.

PipeCut P400 pipe saw is intended for short, intermittent use. The machine may be loaded for 2,5 minutes during a 10-minute period (S3 25 %). PipeCut P400 pipe saw is not intended for use in industrial serie production.

Product Features

While reading the operating instructions, unfold the graphics page for the machine and leave it open. This page is folded under the cover of this manual (page 3). The following numbering of the product features refers to this illustration.

Figure A

1. UNLOCK button
2. Power switch
3. Power switch locking lever
4. Motor unit
5. Moving blade guard lever
6. Blade guard cover
7. Setting points
8. Straight adjustment screw
9. Moving blade guard
10. Operating handle
11. Blade guard screw
12. Spindle lock button
13. Allen key
14. Rating plate
15. Overload protection
16. Straight adjustment screw indicator
17. Steering unit
18. Safe for the steering unit
19. Adjustment knob for the steering unit
20. Steering unit indicator

Exact P400 pipecutting system operating instructions

Before operating the Exact P400 please do as follows

Check that the motor unit is in the upright position so that the yellow mark on the UNLOCK button is visible.

Check that there is correct blade in the machine. Check that the blade is correctly in place and tightly fixed well and that it is in good condition.

Cut Bevel blade might get loose because of vibration during cutting.

Check that the guide wheels are rotating.

Check that the support wheels are rotating.

Check that the lower blade guard is moving correctly.

Check that the pipe intended to be cut is empty.

Connecting the Exact P400 to the main power supply

Ensure that the mains voltage is the same as indicated on the rating plate (Figure A/14)

Connect the Exact P400 to the power outlet only

after having checked the list above.

Setting the supports for the pipe to be cut.

Always use Exact pipe supports when sawing. The supports maximise safety and optimise the cutting result. The cutting should always be done on a flat surface. Place the pipe on the sawing support so that the cutting point is between the wheel pairs. Place the single supports underneath both ends of the pipe. Make sure that all of the wheels are in contact with the pipe. If necessary wedge the holders with a piece of wood. (Fig. B) Shorter sections (under 25cm/10") can be cut with two supports placed so that the cutting point is outside the supports. (Fig. C) By sawing in the correct order you prevent the saw blade from jamming in the pipe in the final stage of the cutting process.

Setting and marking the cutting point

Use a marker to mark the cutting point. There are two setting points on the moving blade-guard of the saw. One is for the blade that only cuts the pipe off (Fig. D/1) while the other is for the blade that cuts and provides a bevel on the end of the pipe. (Fig. D/2)

To start sawing

Open the safety screw (Fig. E1) and adjust the wheel pairs in the Exact P400 steering device according to the diameter of the pipe by rotating the adjustment knob on the back of the Exact P400 (Fig. E2). The scale on the saw is approximate. User can fine tune the length of the bevel with the adjustment knob. Please notice that the smaller the diameter of the pipe the more sensitive the adjustment of the depth of the bevel will be.

Fig. B

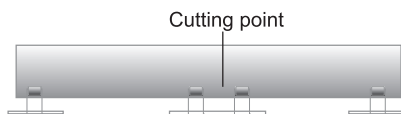


Fig. C



Fig. D

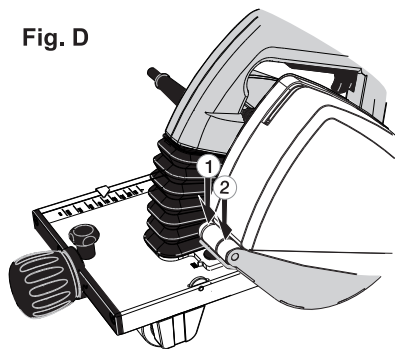
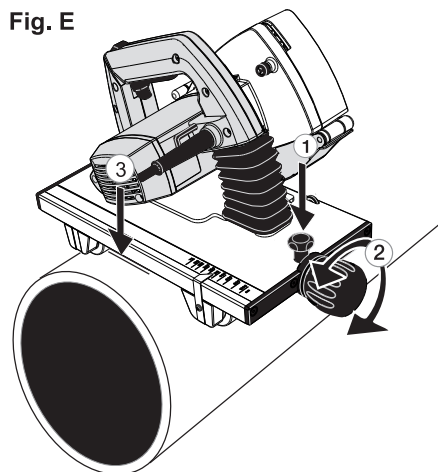


Fig. E



It is most important that the base of the steering device does not touch the pipe but rather that the wheel pairs support the saw (Fig. E3). Finally lock the adjustments with the safety screw (Fig. E1) so that the adjustments do not alter during the sawing.

Pull the lever on the moving bladeguard to an towards you. (Fig. F and A/5) Place the Exact P400 horizontally on top of the pipe so that a suitable setting mark for the blade that is in the machine is positioned at the cutting point (Fig F). Hold the pipe in place and ensure that the Exact P400 moves freely in the direction the pipe is fed. To ensure safety the Exact P400 leads should be to the left and front of the pipe. The Exact P400 is now ready for use.

Piercing the pipe wall

Strive to keep the P400 in a horizontal position on top of the pipe during the entire sawing process. Take a firm hold of the operating handle with your right hand, start the motor by releasing the locking lever on the power switch (Fig. G/1) and push the power switch all the way down (Fig. G/2). Before starting to saw wait until the blade reaches full speed. Pierce the pipe wall by pressing the operating handle down slowly until the blade has cut through the pipe wall (at this stage the pipe must not rotate) and the motor unit has locked into sawing position. When the UNLOCK button is locked, i.e. the yellow mark disappears (Fig. H), the Exact P400 is locked and you can safely start sawing around the pipe. When using a CutBevel blade piercing must be performed especially calmly.

Sawing around the pipe

Start sawing by rotating the pipe with your left hand towards yourself (Fig. I) and keep the Exact P400 stable and in a horizontal position in relation to the pipe (Fig. J). Continue sawing by rotating the pipe calmly and at the most even speed possible towards yourself until the pipe is cut off.

If you use a CutBevel blade continue sawing approximately 5 cm after the pipe has been cut off. This will ensure an even bevel around the entire pipe. If you bevel an additional round you will get even better result. Large bevells have to be done always with two rounds. First round should be cut so that the bevel is not complete, and with second round the steering unit should be adjusted to the desired bevel length. Note that the temperature has effect to the hardness of plastic

The saw can also be steered manually if the blade does not coincide with the initial cut. When you see the starting point of the cut, turn the saw at a gentle angle towards the initial cut until the pipe is cut off (Fig. L)

Fig. F

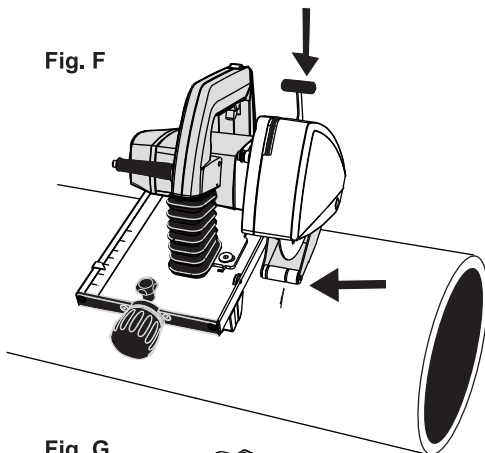


Fig. G

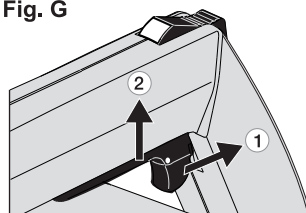


Fig. H

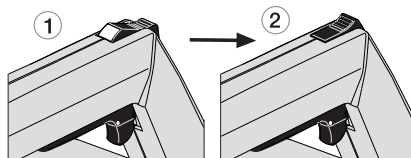
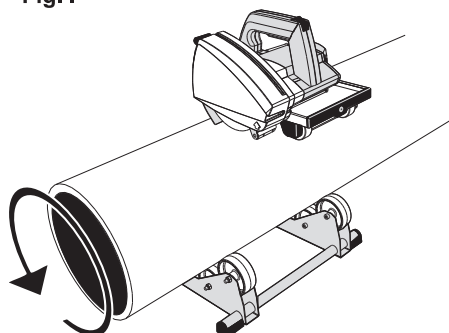


Fig. I



When the pipe is cut off, push the UNLOCK button forward until the yellow mark is visible and the locking is released (**Fig. L**). Now raise the motor unit to starting position. Release the power switch. After the saw is lifted away from the pipe ensure that the moving blade guard has turned into safety position (**Fig. M**).

Select the feeding speed as per the material and the thickness of the wall. Too high speed can damage the blade, overload the Exact P400 and give a poor sawing result. Especially when using a CutBevel blade the feed rate should be fairly slow to ensure a quality bevel finish.

The Exact P400 can also be used for making only a bevel to the end of plastic pipe. First position the saw on top of the pipe so that the cutting blade of the CutBevel blade is at the end of the pipe. (**Fig. N**) Now you can work the pipe as previously described.

Should there be problems during piercing or sawing, abnormal sounds or vibrations due to which you have to interrupt sawing before the pipe is cut through, release the blade by pushing the UNLOCK button forward until the UNLOCK button is released and lift the motor unit up. Once the problem is cleared, start sawing again.

Never start the motor when the motor unit is locked in sawing position or the teeth of the blade are in contact with the sawn pipe.

Always clean the steering device and the guide wheels after use. This will ensure that plastic chips caught in the wheels do not skew the unit and cause a lopsided cut.

Overload protection

The Exact P400 is equipped with overload protection. When the blade is dull or the cutting speed is too high, the overload protection cuts power automatically. Restore the power by pushing the overload protection switch (**Fig. A/15**).

Straightness of the cut and the adjustment

The cut is affected by many factors, e.g. the size of the pipe, the material, the wall thickness, the quality of the pipe's surface, the roundness, blade condition, feed rate, the operator's experience. The cutting result may vary and a gap may result on the cutting surface either to the right or left i.e. the difference between the start and end point of the cut (**Fig. O**).

There is a feature in the steering device of the Exact P400 (**Fig. A/8**) which, if needed, can improve the sawing result and facilitate to reach the placement of the initial cut.

Fig. J

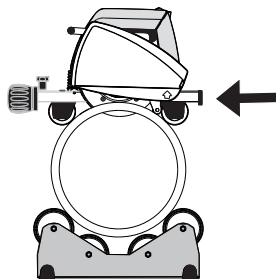


Fig. K

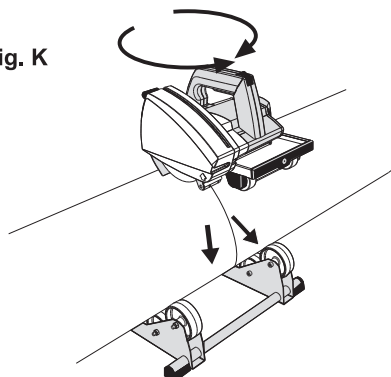


Fig. L

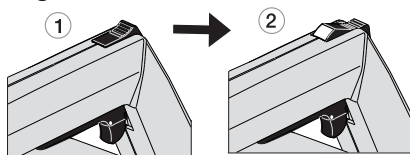
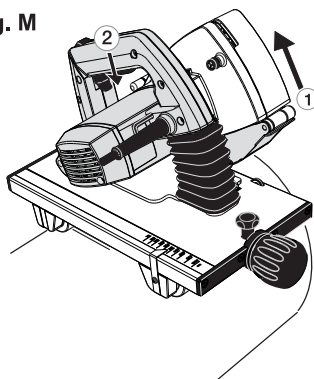
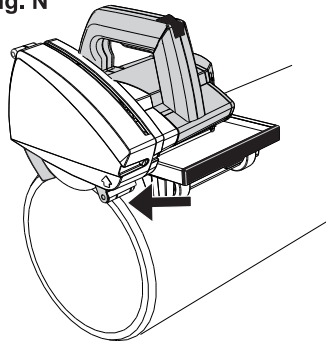


Fig. M



Loosen the locking screw (**Fig.P/1**) with the M5 allen key on the handle of the Exact P400. There is an adjustment wheel on the right hand side of the steering device (**Fig. P/2**). Turn the wheel with your finger either clockwise or anti clockwise. The direction depends on the direction of the misalignment. This adjustment turns the entire motor unit in relation to the steering unit. There is also an arrow and a dial on the steering unit. (**Fig. P/2**) These will help to gauge the extent of the adjustment. Adjust the motor unit to the desired direction to correct the sawing error. The extent of the adjustment depends on the extent of the error, pipe diameter as well as the strength and material of the pipe wall. Tighten the locking screw (**Fig. P/1**) after the adjustment.

Fig. N



Installing and changing the saw blade

⚠ WARNING: To reduce the risk of injury, turn unit off and disconnect it from power source before installing and removing accessories, before adjusting or when making repairs. An accidental start-up can cause injury.

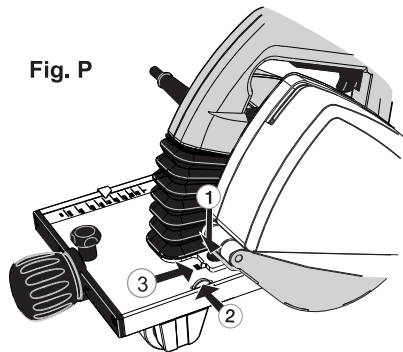
Remove the power plug from the socket. Check that the motor unit is locked in the upper position.

Remove the blade guard cover (**Fig. Q/1**) by opening the screw (**Fig. Q/2**). Press the spindle-lock button (**Fig. A/12**) and simultaneously rotate the blade by hand until the spindle-lock button drops a further distance of about 4 mm. Now the rotation of the blade is prevented. Use the blade key to open the blade attachment bolt. Remove the securing bolt (**Fig. Q/3**), the washer (**Fig.Q/4**), the blade flange (**Fig. Q/5**), and the blade (**Fig. Q/6**).

Fig. O

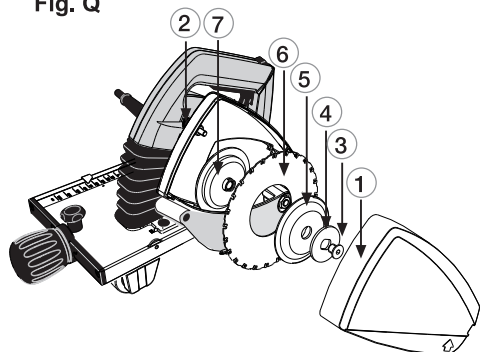


Fig. P



Before installing a new blade, check that both blade flange discs are clean. Place a new or sharpened blade on the lower blade flange (**Fig. Q/7**), so that the marked side of the blade is facing outwards and the arrows on the blade are facing in the same direction as the rotation direction markings on the inside of the blade case. Ensure that the new blade goes right to the bottom in the lower blade flange. Put the blade flange, the washer, and the securing bolt back in place. Press the spindle lock button and tighten the blade securing bolt. Put the blade guard cover back in place and tighten the screw.

Fig. Q



Maintenance and servicing instructions

Remove the power plug from the socket before servicing or cleaning the pipe saw. All maintenance operations carried out on the pipe saw's electrical components must be carried out at an approved service agency.

Blade

Check the condition of the blade. Replace a bent, blunt, or otherwise damaged blade with a new one. Using a blunt blade can overload the pipe saw's electric motor. When you notice that the blade is blunt, do not continue sawing with it, as the blade may become so badly damaged that it will not be worth sharpening. A blade in sufficiently good condition can be sharpened a few times by a professional sharpening company.

Steering unit

Clean the steering unit regularly with compressed air and after every cut wipe out the chips with a brush.

Blade guard

Make it a rule to clean the blade guard regularly, and pay special attention to keep the moving blade guard movement from becoming hampered.

Motor

Keep the motors cooling vents clean.

Plastic parts

Clean the plastic parts with a soft rag. Only use mild detergents. Do not use solvents or other strong detergents as they may damage the plastic parts and paint surfaces.



Power cable

Check the condition of the power cable regularly. A faulty power cable should always be replaced at an approved service agency.

Correct use and regular servicing and cleaning will ensure the continued operation of the pipe saw.



Environment



Separate collection. This product must not be disposed of with normal household waste. When your Exact PipeCut P400 machine is worn out, do not dispose of it with normal household waste. This product must be recycled separately. Separate recycling of used products and packaging facilitate recycling and recovery of materials. Reusing of recycled materials helps prevent pollution of environment. According to local regulations it is possible to deliver household appliances to municipal rubbish depositories or to the dealer when buying a new product.

Guarantee

Warranty terms valid from 01.01.2015

If the Exact PipeCut Saw becomes unusable due to material or manufacturing defects within the Warranty Term at our discretion we will repair the Exact PipeCut Saw or supply an entirely new or factory reconditioned Exact PipeCut Saw at no charge.

Warranty Term

The Exact Tools Warranty Term is for 12 months from date of purchase.

The Warranty is only valid if:

- 1.) Copy of a dated purchase receipt is returned to the Authorized Warranty Repair Center or has been uploaded to our website at the time of warranty registration.
- 2.) The Exact PipeCut Saw has not been misused.
- 3.) No attempt has been made by non-approved persons to repair the saw.
- 4.) The Exact PipeCut Saw has been used in accordance with the operating, safety, and servicing instructions provide in the manual.
- 5.) The Exact PipeCut Saw has been delivered to an Authorized Warranty Repair Center within the term of the warranty.

Note: The Exact PipeCut Saw is to be shipped to the Authorized Warranty Repair Center freight prepaid. If the Exact PipeCut Saw is repaired under Warranty the return shipment will be made freight prepaid. If the Exact PipeCut Saw is not repaired under Warranty the return shipment will be made freight collect.

Please Note: The following items or services are excluded from Warranty claims:

- Saw Blades
- Overload Protection Fuse
- Carbon Brushes
- Gripping Unit Wheels
- Blade Flange
- Attachment Flange
- Pulling Flange Washer
- Normal Wear and Tear
- Errors Due to Misuse or Accident
- Water, Fire and Physical Damage
- Power Cords
- Adjustment of Adjustment Wheel

Due to continuous product development, the information in this instruction book may change. We do not give separate notification of changes.

Tips for using Exact PipeCut saws

All these tips may not concern every Exact model

Diamond blade should only be used for cutting cast iron pipe. It is not recommended to cut cast iron with TCT or Cermet blades.

Clean the inside of the blade guards after cutting plastic pipe.

Smaller pipe is easily cut by rotating the pipe by hand either on a table or on the floor. Please note: rotate pipe towards you when rotating by hand and be careful not to rotate too fast.

Check the condition of the blade regularly.

The cutting procedure is divided into two stages; first saw through the pipe wall, then complete the cut by sawing around it.

Do not overload the saw by cutting continuously. The saw will be overheated and the metal parts can become burning hot. This will also damage the motor and the blade. The rule is 2,5 minutes in use and 7,5 minutes rest.

Keep the feeding speed constant. This will extend the lifetime of the blade. For example cutting time for a steel pipe diameter of 6" (170mm), and a wall thickness of 1/5" (5mm), is 15-20 seconds, and for a cast-iron pipe diameter of 4" (110mm), with a wall thickness of 1/6" (4mm) is 20 to 25 seconds.

Always keep the motor unit in the upright position. The yellow mark of the unlock button is then visible. Never place the Pipe Cut Saw on the pipe in the locked / cutting position.

Factors that affect the lifetime of the saw blade:

- material of the pipe
- correct blade type for material being cut
- correct motor speed setting (model 170E)
- wall thickness of the pipe
- feeding speed
- smoothness of the pipe
- user's general skills
- cleanness of the pipe
- rust on the pipe
- welded seam in the pipe
- blade speed

Factors that affect the straightness of the cut:

- condition of the saw blade
- wall thickness of the pipe
- feeding speed
- smoothness of the feed
- user's general skills
- cleanness of the pipe
- roundness of the pipe
- gripper unit too loose or too tight
- blade assembled too tight

Please see more information at our web-site

www.exacttools.com

exact

Exact Tools Oy

Särkiniementie 5 B 64

FI-00210 Helsinki

Finland

Tel +358 9 4366750

Fax +358 9 43667550

exact @exacttools.com

www.exacttools.com